



**HAL**  
open science

## Adobe, manuel of production : tropical - humid area

Wilfredo Carazas Aedo, Alexandre Douline

► **To cite this version:**

Wilfredo Carazas Aedo, Alexandre Douline. Adobe, manuel of production : tropical - humid area. [Technical Report] CRATerre; Misereor. 2004, pp.13. hal-03173980

**HAL Id: hal-03173980**

<https://hal.univ-grenoble-alpes.fr/hal-03173980v1>

Submitted on 21 Jul 2021

**HAL** is a multi-disciplinary open access archive for the deposit and dissemination of scientific research documents, whether they are published or not. The documents may come from teaching and research institutions in France or abroad, or from public or private research centers.

L'archive ouverte pluridisciplinaire **HAL**, est destinée au dépôt et à la diffusion de documents scientifiques de niveau recherche, publiés ou non, émanant des établissements d'enseignement et de recherche français ou étrangers, des laboratoires publics ou privés.



Distributed under a Creative Commons Attribution - NonCommercial - NoDerivatives 4.0 International License



MISEREOR

# ADOBE

## MANUEL OF PRODUCTION

Tropical - humid area

Wilfredo CARAZAS AEDO  
Alexandre DOULINE



CRATerre  
Editions



## FOREWORD

This manual was designed for the builders, technicians, professionals involved in rural housing development programmes in humid tropical climates where :

- Rainfalls are important
- Clay content of the soil is very high
- Existing building techniques are based on the use of adobe blocks as in-fill material :
  - . Wooden structure filled with adobe for rural housing.
  - . Concrete structure filled with adobe or burnt bricks for public buildings.

In these regions, adobe blocks are often considered as :

- A rare material
- A copy of the burnt brick
- A copy of the cement block

Thus, the adobe technique is not considered as a specific technology with its own characteristics, and both the production cycle and the building details are not well mastered.

Finally, few technicians understand the rules of bearing masonry walls, as they are influenced by the framework system.

### THE SQUARE BLOCK:

In hot and humid climates where soils are very clayey, it is recommended to produce square blocks to reduce the risk of cracks.

The proposed dimensions are based on the conventional building materials:

- Double size of the local burnt bricks, Example: 22 x 22 x 9 cm. or 9" x 9" x 4"
- Half size of the local cement block, Example: 20 x 20 x 10 cm.

The square format is well adapted to teach the rules of bearing masonry.

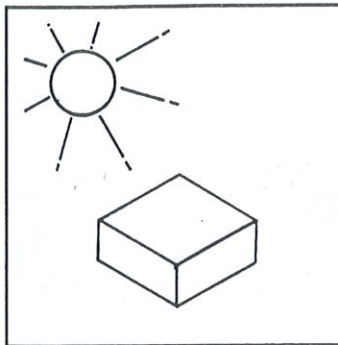
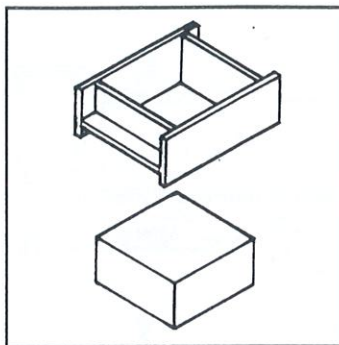
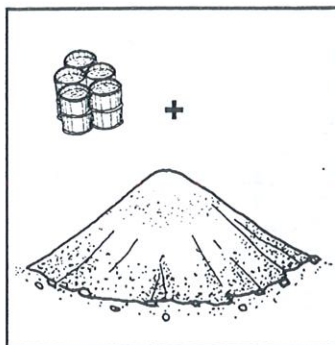

The adobe production basically consist in moulding soil prepared in a plastic state and drying it naturally on the ground.  
The necessary quantity of water is about one fourth of the dry earth volume.

Square block

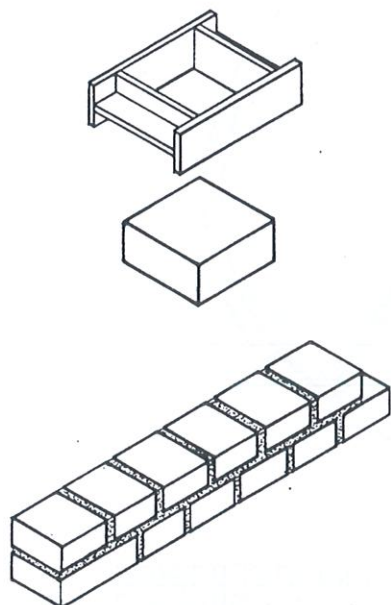

'One and a half' block

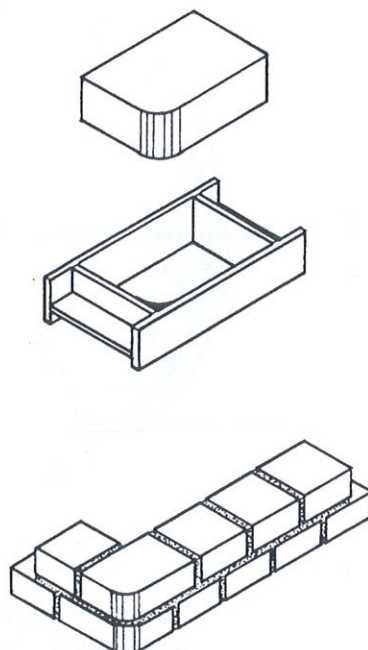

U-Shape block

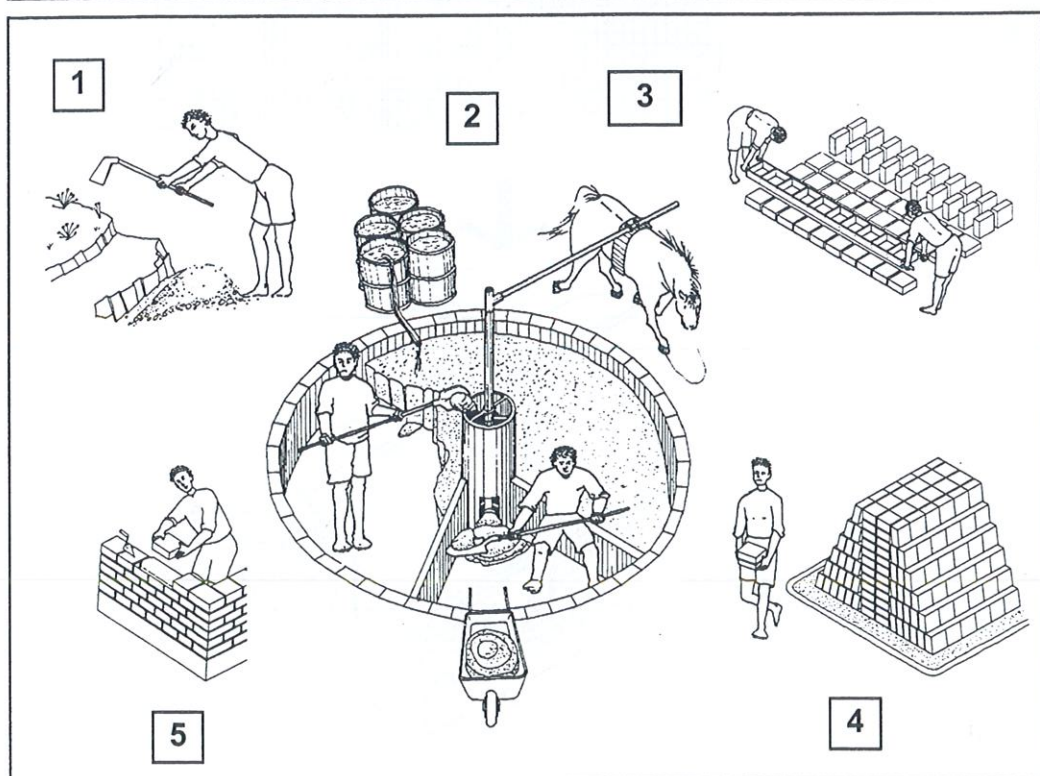
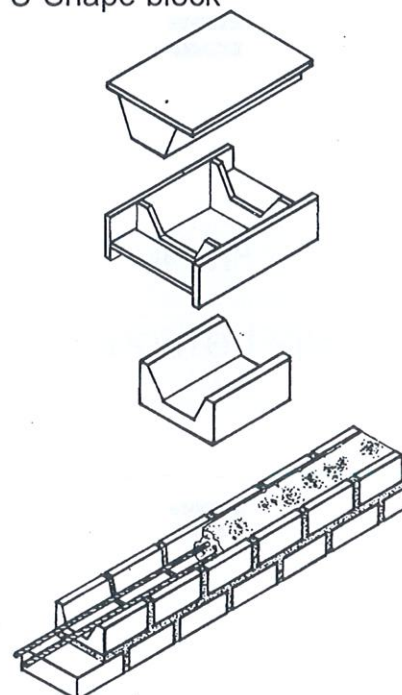

**ADVANTAGES**

- Availability of the raw material on a local level.
- Very cheap basic production equipment.
- no fuel is required to bake

**DISADVANTAGES**

- Very water consuming.
- Large drying space needed.
- Drying time dependent from the climat.
- Blocs with low water resistance.



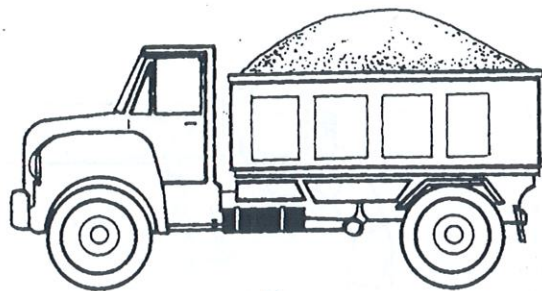

**5 m<sup>3</sup>**  
Extracted soil  
+  
**1 m<sup>3</sup>** of water

**=**

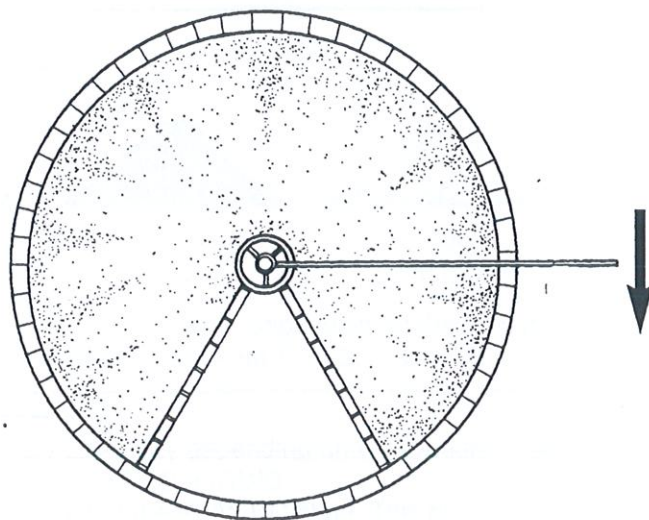

**4 m<sup>3</sup>**  
Prepared soil

**=**

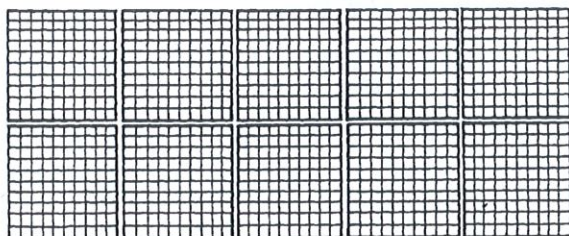

**1 100 ADOBES**  
20 x 20 x 9 cm

**=**

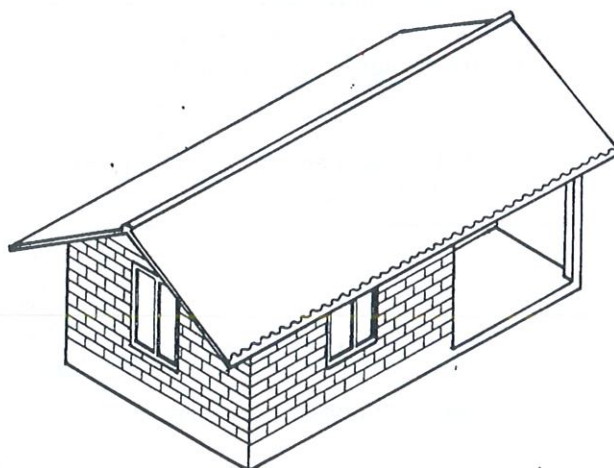

**25m<sup>2</sup>**  
brickwork

**ORIGIN**

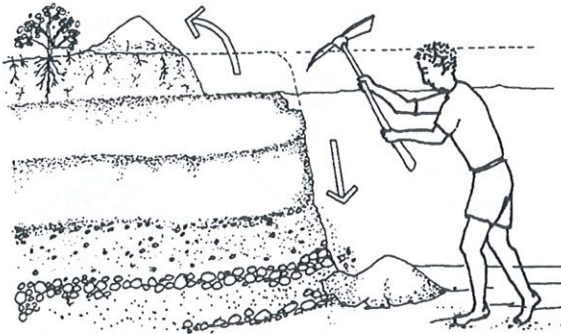

Soil is the loose material that results from the mechanical and chemical erosion of the underlying parent rock. This rock crumbles into mineral particles of very variable sizes going from the stones to the clayey ashes. In the upper layer, these particles are mixed with the organic material coming from the decomposition of the living world. This "organic" soil is reserved to agriculture. The other layers are used for construction.

**COMPONANTS**

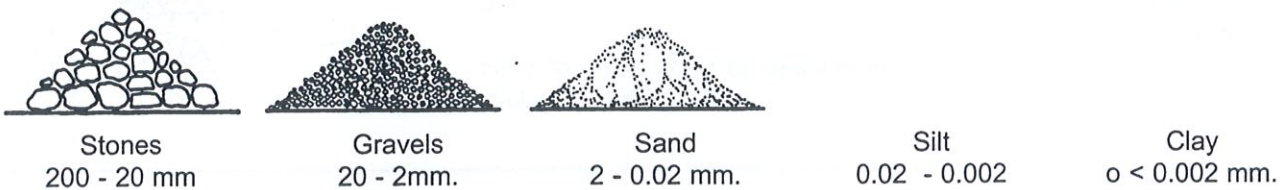

Different types of soil can be found, depending on the importance in quantity of one of the components: GRAVELLY SOIL - SANDY SOIL - SILTY SOIL - CLAYEY SOIL.

**HYDROUS STATES**

A soil will react very differently depending on the amount of water it has absorbed. The 4 fundamental states are: DRY - HUMID - PLASTIC -LIQUID. The adobe is produced at the PLASTIC state. This hydrous state enables the soil to be shaped without deformation until it comes back to the DRY state.

**COHESIVE PROPERTIES**

To shape adobe we use the property of COHESION, which works in 2 phases:

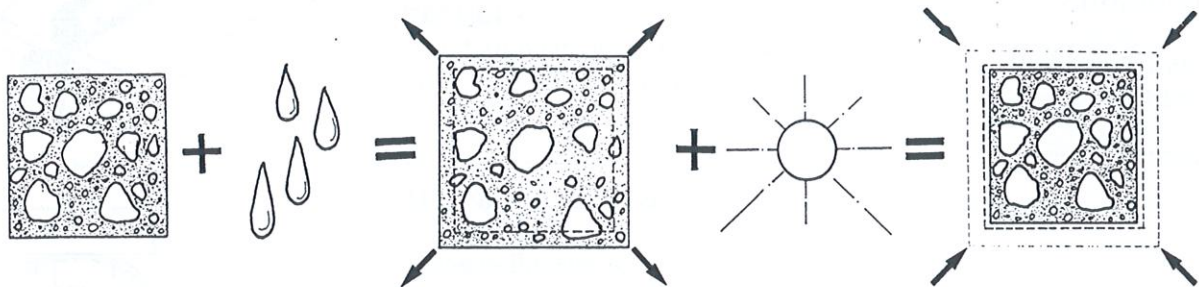

Phase 1: The soil absorbs the water (from 20 to 30 %, according to the type of earth), the clays start to swell, this process is long and takes time. Phase 2: The soil dry, the clays reduce their volume and carry the other materials that finish, at the dry state to be completely bonded.

If the inter-penetration between grains is such that only a few voids remain, then once the soil is dry, it is able to support compressive stresses of about 3 MPa.

**STABILIZATION**



When the soil is clayey, it may shrink after drying.

- Possible correction :
- add sand in order to reduce the cohesion.
  - mix with straw in order to reduce the size of the cracks.



### OBJECTIVE

Determine whether the soil is convenient for adobe.

The more simple way is to mould adobes and to analyse their behaviour after drying (aspect, cracks, resistance)  
If you lack time, the field tests can help to select the best soil.

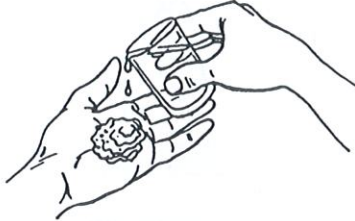

### TOUCH AND SMELL TESTS

- With water, our senses can identify the components of the soil:

Emanation of a smell: **ORGANIC soil**

Rough, crumbly, not very sticky: **SANDY soil**

Fine, easy to break into powder, sticky: **SILTY soil**

Hard to crush, long to dissolve into water, very sticky: **CLAYEY soil**

### SUITABILITY:

The ideal soil would be both clayey and sandy.

Take care of the silty soil because once they are dry, they do not resist to water.

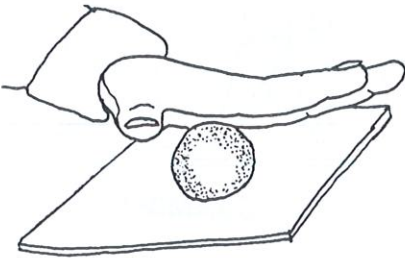

### THE "CIGAR" TEST

- Remove all gravels from the sample.
- Moisten, knead it well and leave to stand for half an hour to allow the clay to react with water.
- The soil must not dirt too much the hands.
- Roll on a board into a cigar-shape 3 cm in diameter.
- Push gently the cigar forward.
- Measure the length of the piece which breaks off.
- Repeat 3 time and work out the average.

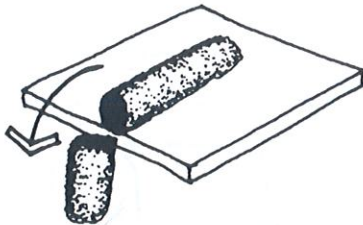

### RESULTS:

less than 5 cm, it is **TOO SANDY**  
more than 20 cm, it is **TOO CLAYEY**

### SUITABILITY:

Between 7 and 15 cm.  
Good soil

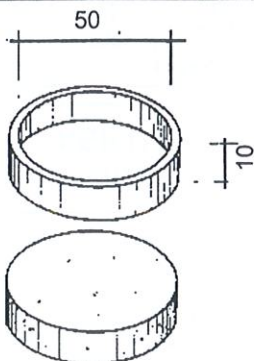

### THE "BISCUIT" TEST:

Retrieve the soil sample of the cigar test and mix it at the plastic state.  
Mould it into 2 biscuit-shape discs with a piece of plastic tube or similar.

After drying:

- Observe any sign of shrinkage.
- Evaluate the soil resistance by breaking and crushing between the thumb and the forefinger.



### RESULTS:

- No shrinkage, easy to break into powder: **TOO SANDY**  
- Shrinkage, easy to break into powder: **TOO SILTY**  
- Important shrinkage, very hard to break into powder: **TOO CLAYEY**

### SUITABILITY:

Less than 1 mm shrinkage, hard to break into powder:  
Good soil





WITH THE FEET



This is the more common way of mixing for a small-scale production.  
4 m<sup>3</sup> /day/man

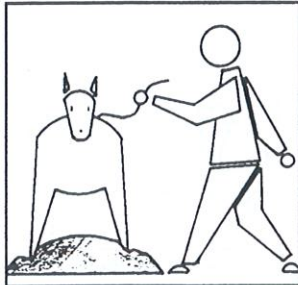

ANIMALS

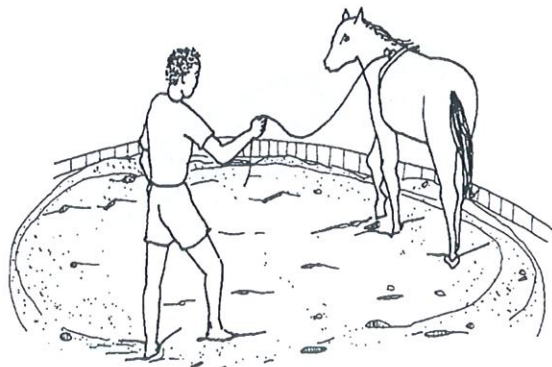

Animals that turn round on the working area can do the footing.

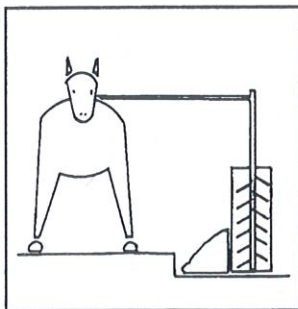

VERTICAL MIXER

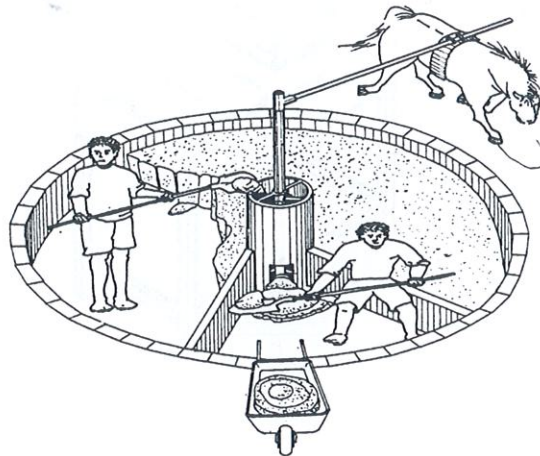

Manufacture with simple meanings, this mixer is powered by animals.

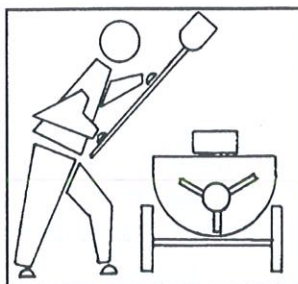

LINEAR MIXER

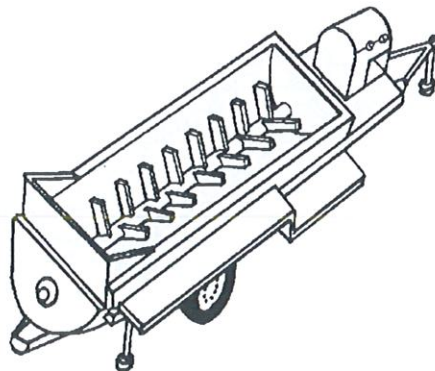

Used in the medium and large-scale production unit.

From 5 to 50 m<sup>3</sup> / day



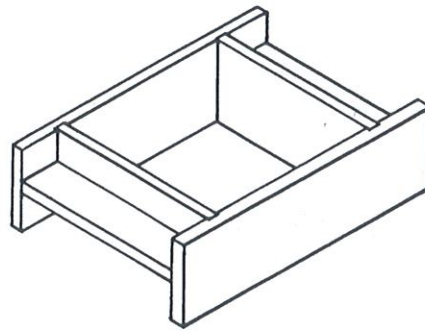
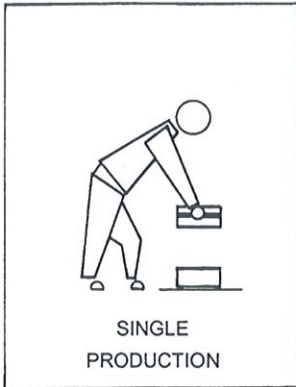

Single production of adobe is made directly on the drying yard.

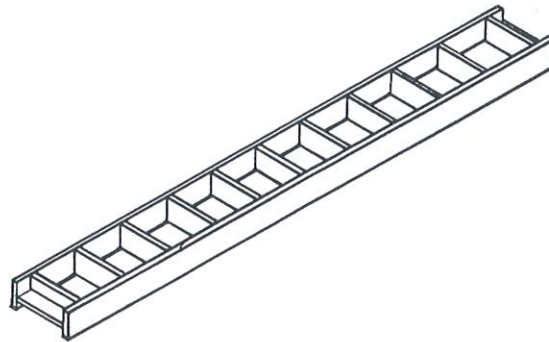
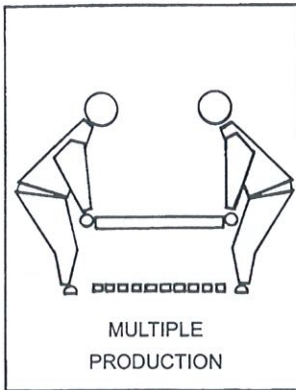

Ladders can be used when the drying yard is flat and large enough.

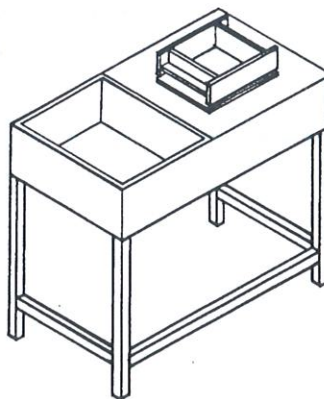

A moulding table offers a comfortable station to work. The block is transported in its mould to the drying yard.

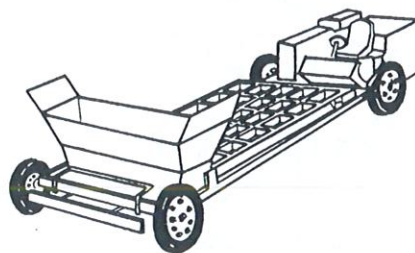

A metallic mould containing a large number of compartments can produce more than 10'000 adobes per day.



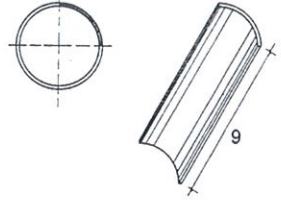
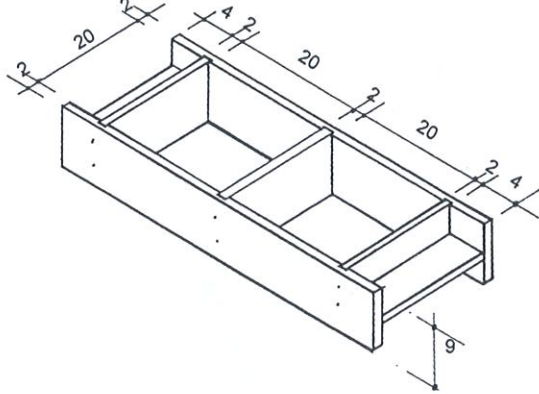
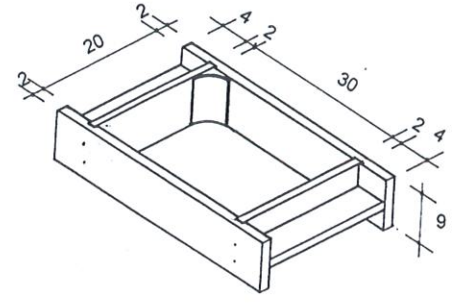
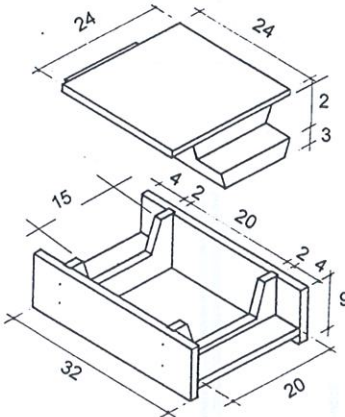

Round corner detail:  
Plastic tube  
of 10 cm in diameter

Wood for 3 basic moulds  
2 of 235 x 9 x 2cm.  
1 of 30 x 15 x 5.5cm.  
1 of 24 x 24 x 1cm.

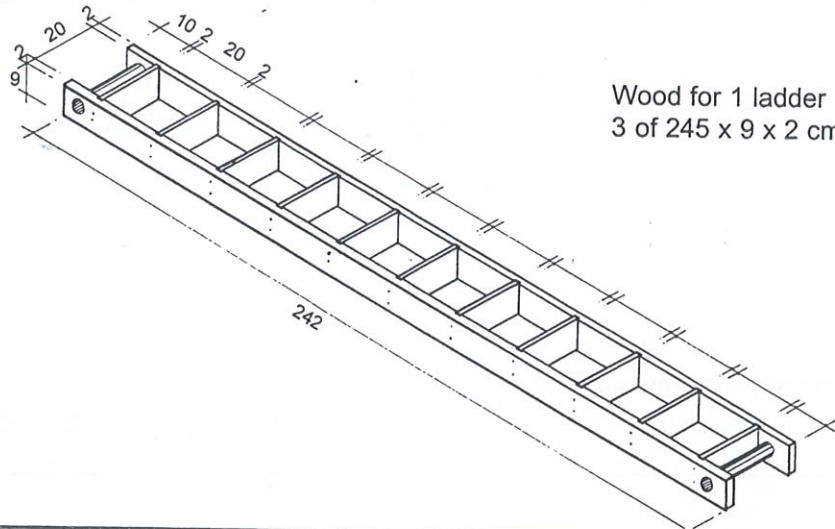
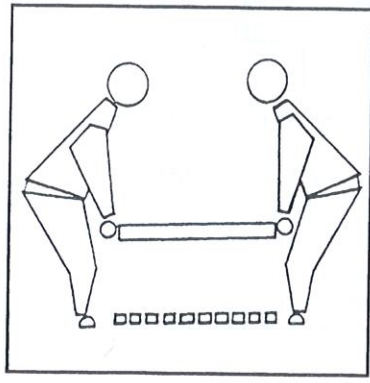

Wood for 1 ladder  
3 of 245 x 9 x 2 cm.

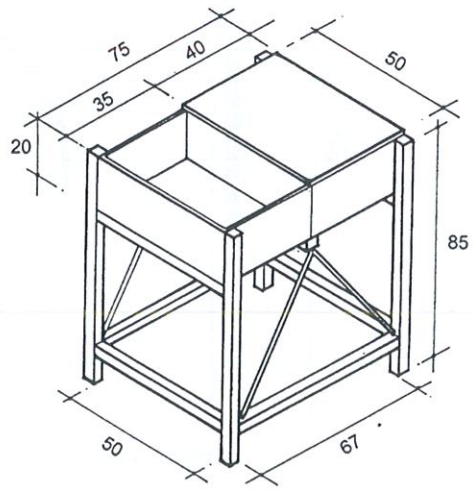

Wood for the table  
4 of 4 x 4 x 85 cm.  
7 of 4 x 4 x 50 cm.  
2 of 40 x 1 x 20 cm.  
1 of 50 x 1 x 20 cm.  
1 of 50 x 40 x 1 cm.  
Steel tank, thickness:  
2 mm.  
Dimension: 20 x 50 x 35 cm.



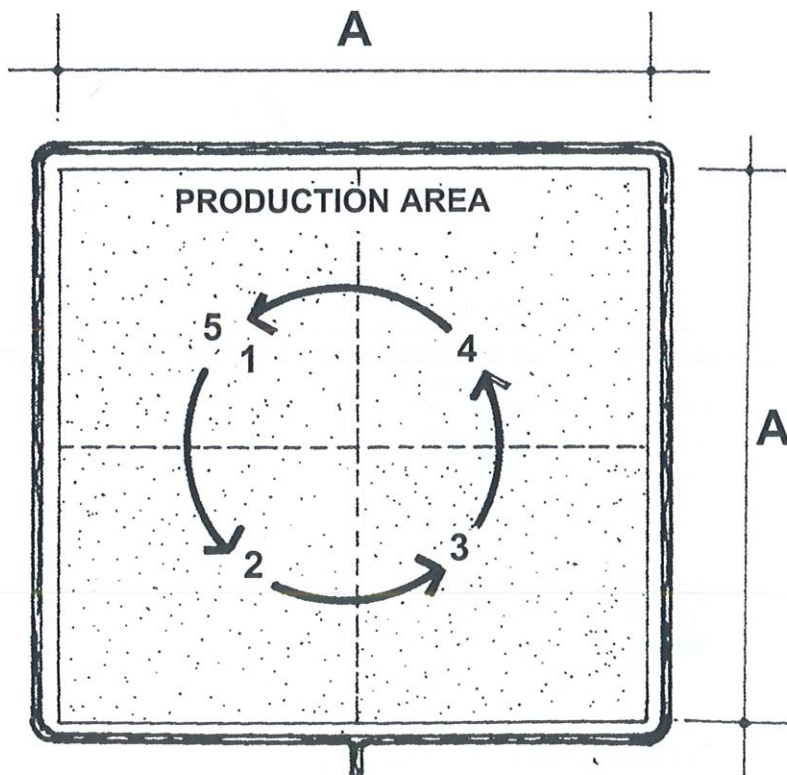
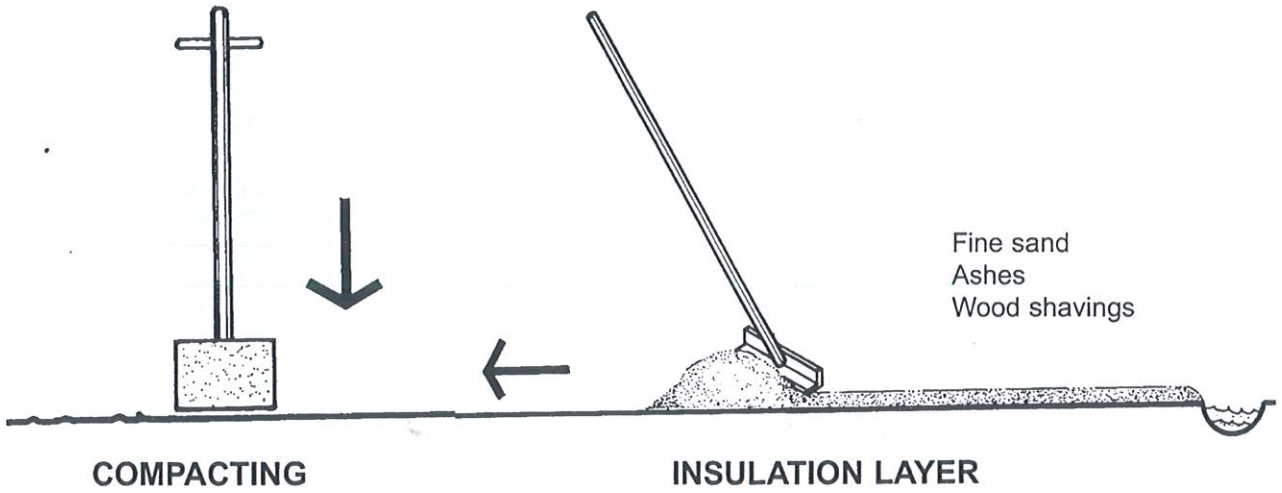
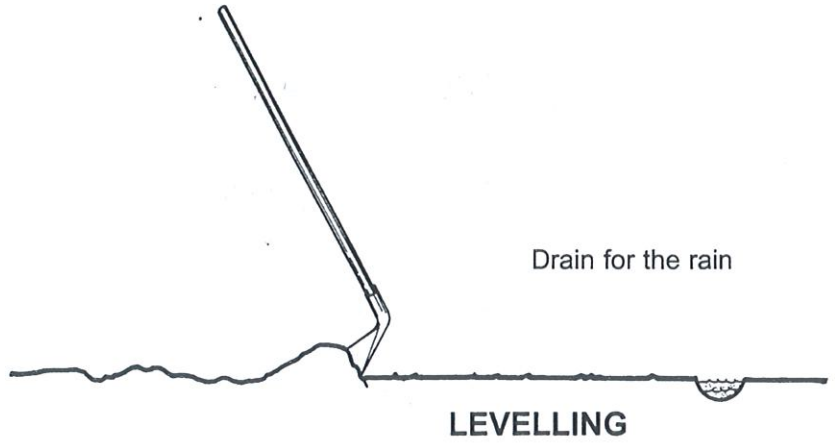

The height of the adobes mainly depend upon the preparation of the drying yard.

EXAMPLE:

- A = 15 metres
- = 4 days of production
- = 4 x 800 (20x20x9)
- = 3 days of drying.



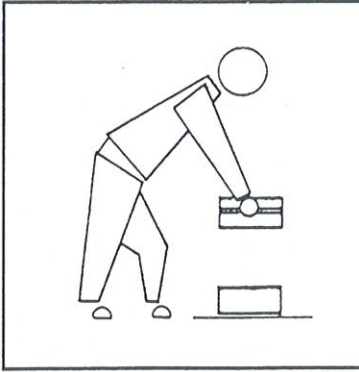

Plan a circulation space every meter allowing an access to place a protection over the adobe in case of rains or too hot climate.

For a better space management and the accounting of the blocks, it is important to respect the alignment.

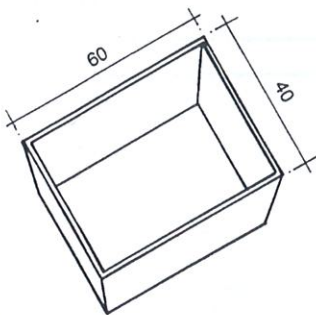
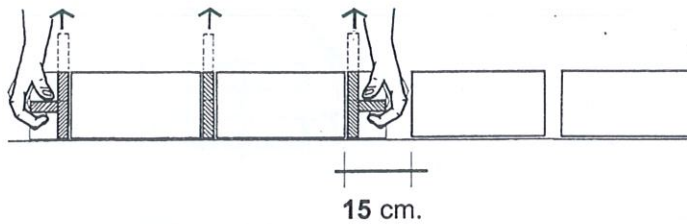
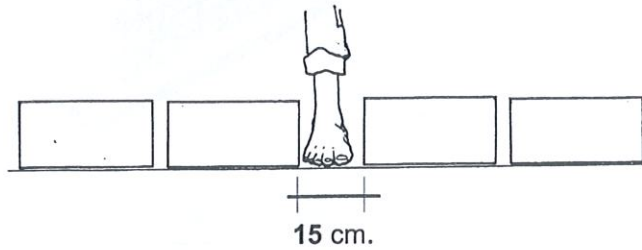
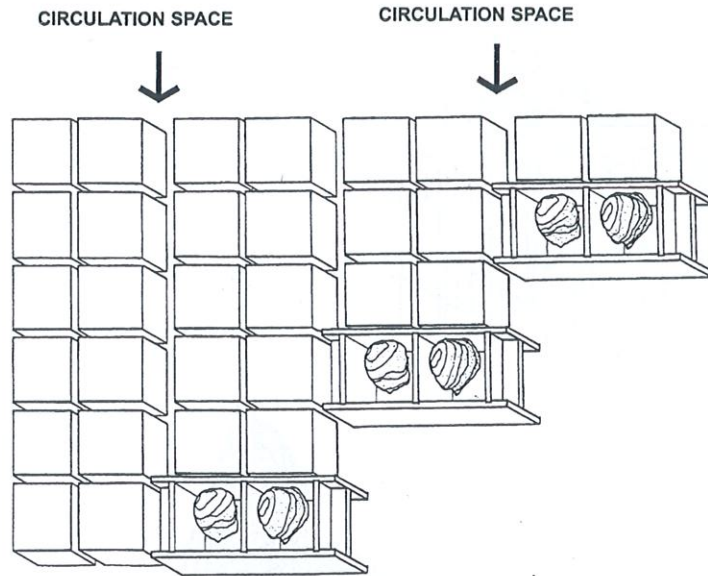

Basin to clean the mould

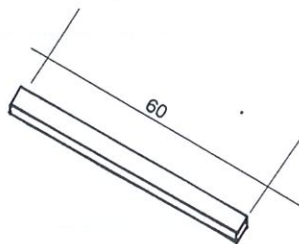

Leveller

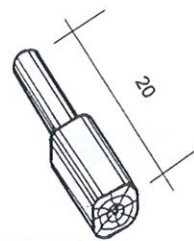

Pestle

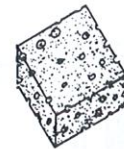

Sponge

TOOLS

PRECAUTIONS AGAINST SHRINKAGE DUE TO HOT CLIMATE

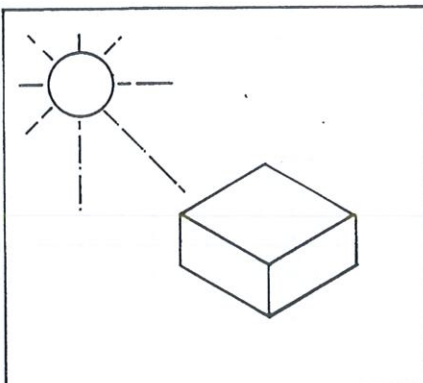

Avoid producing during the hottest hours of the day, between 11hr. and 15 hr.

Protect immediately the surface of the block with a layer of sand or ashes or vegetal mat.

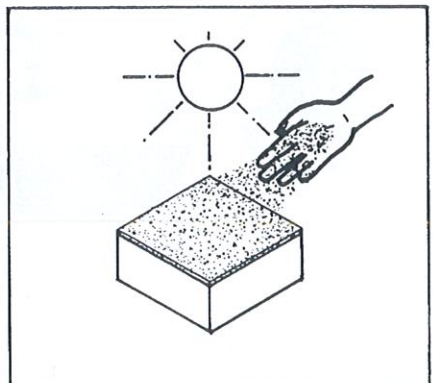

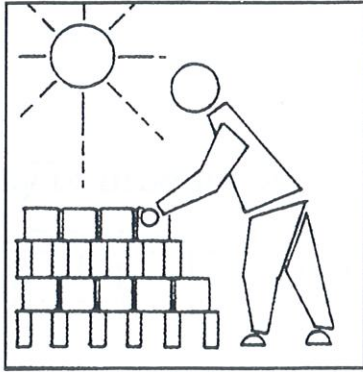

First stocking should allow ventilation for final drying

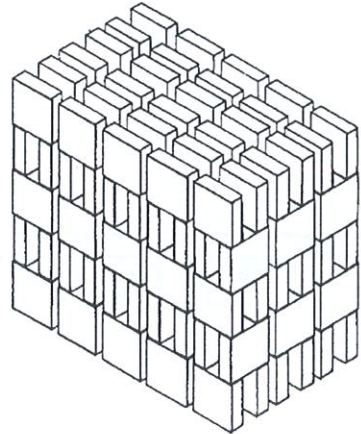

EXTERIOR STOCKING

Types of covering :

- leaves (banana, palm, etc.),
- corrugated iron,
- plastic sheet

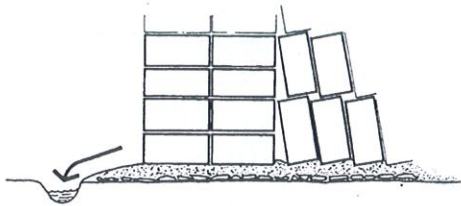
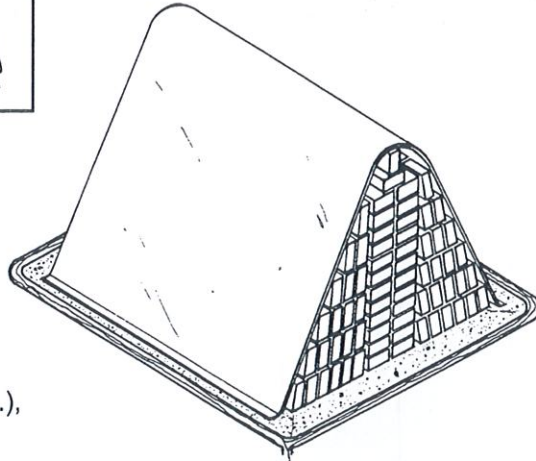

Insulation layer of sand, gravel  
Peripheral drain

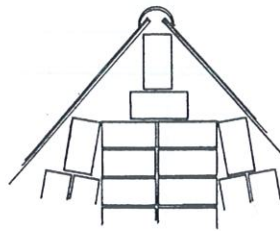

Detail of the top

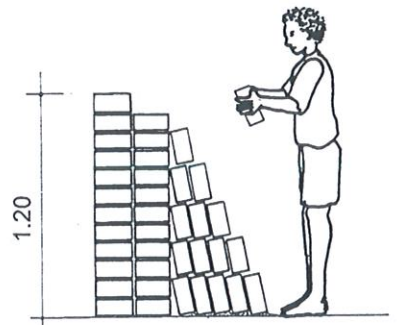

Maximal height

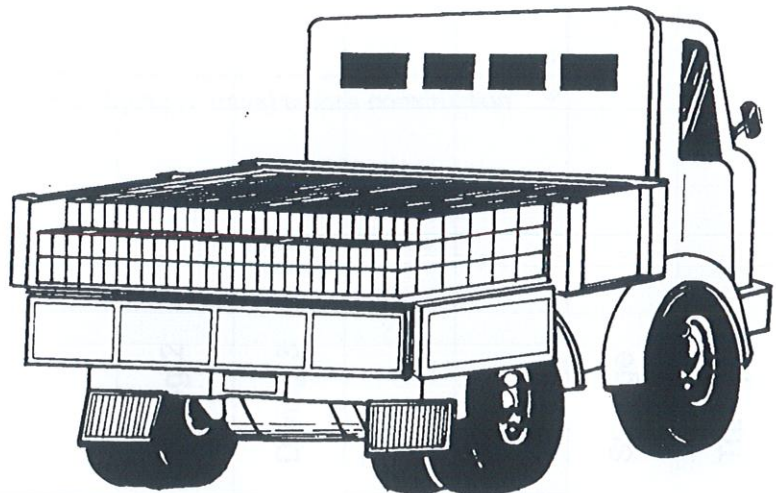
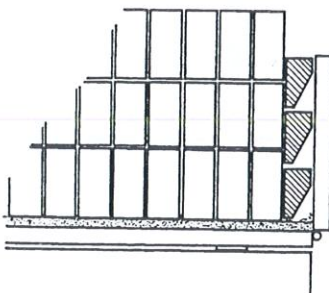
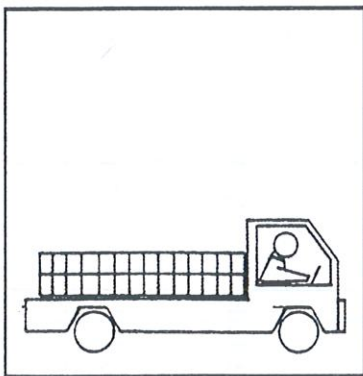

To avoid losing adobes during the transport:

- spread a layer of sand under adobes
- wedge the adobes against the sides of the truck with wood.



Day of production

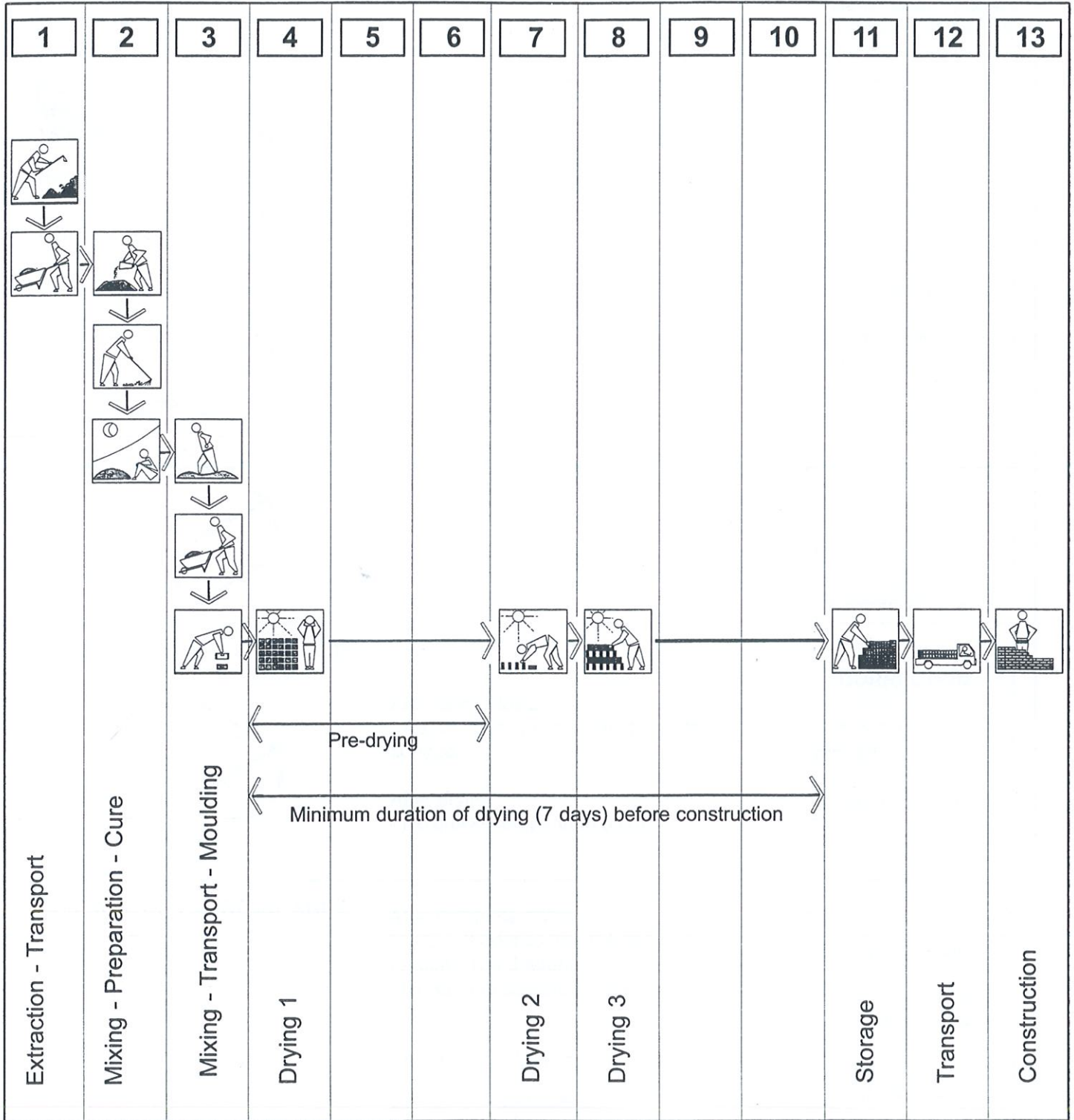

**CONTROL OF THE SOIL**

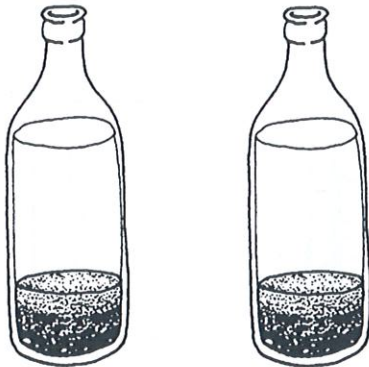

Reference

Sample

During extraction:

Check every week that the new soil is similar to the one you've selected at the beginning.  
Carry out a "bottle test" (settling of the soil into water after shaking)  
Compare the different layers with the reference bottle.

**CORRECTION :**

When the two bottles do not have the same aspect, restart the soil analyses to verify its properties.

**CONTROL OF THE SHAPE**

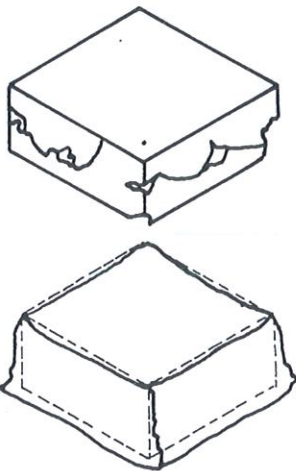

During demoulding:

- No hole is allowed on the edges.

- The base must not increase of more than 5%

**CORRECTION :**

- Better compression of the edges in the mould.

- Reduce the water content of the mix.

**CONTROL OF THE SHRINKAGE**

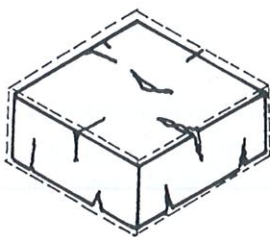

After demoulding:

- Rapid appearance of cracks on the surface.

After drying

- No cracks longer than 5 cm.

**CORRECTION :**

- Protect from the hottest sun

- Stabilise the soil with sand or straw.

**CONTROL OF THE RESISTANCE**

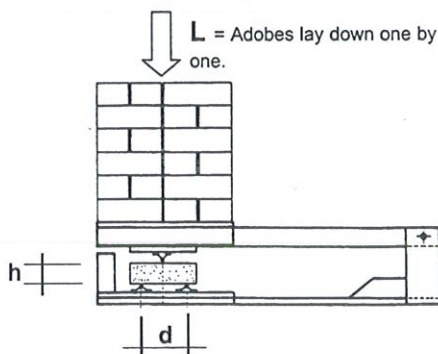

W = width of the adobe

After complete drying:

Choose 3 adobes into the daily stock at random. The 3 adobes must be stronger than what is specified in the "client-contract".

Resistance to bending stress: **RB**

$$RB = \frac{1,5 \times L \times d}{W \times h^2}$$

Example :

Adobe 20 x 20 x 9 cm , d= 15 cm,

Load = number of blocks x 7kg

Good if:

L > 20 blocks (RB > 2,9 kg./cm<sup>2</sup>)

**CORRECTION :**

-Verify the soaking time of the soil before moulding.

- Verify the cohesion of the soil:  
If it is too sandy, change your career.



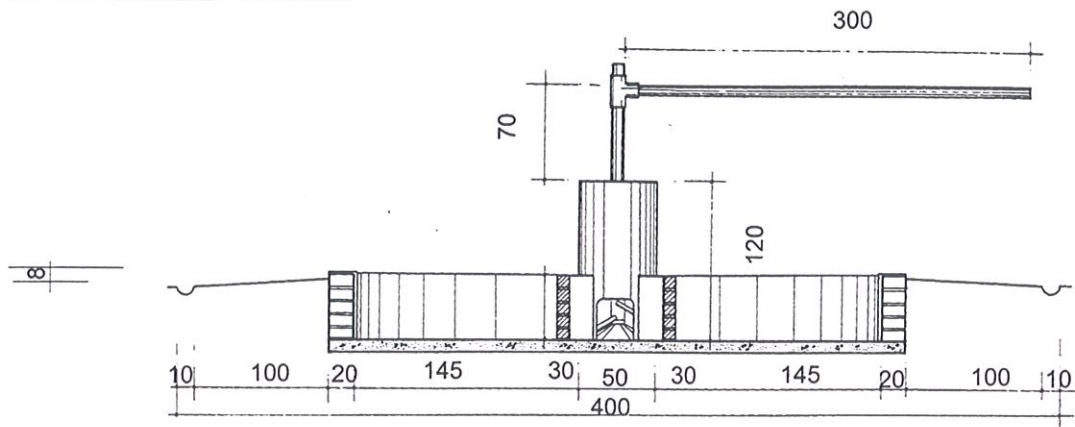
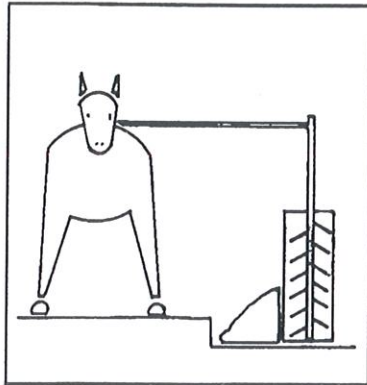

The mixing basin allows the soaking of 4 m<sup>3</sup> of soil during 24 hours.

This one is then mixed in the central tube.

