

Identification of random internal structuring THz tags using images correlation and SIWPD analysis

F. Bonnefoy¹, C. Ioana², M. Bernier¹, N. Barbot³, R. Siragusa³, E. Perret³, P. Martinez⁴ and F. Garet¹

¹Univ. Grenoble Alpes, Univ. Savoie Mont Blanc, CNRS, Grenoble INP, IMEP-LAHC, 73376 Le Bourget du Lac, France.

²Univ Grenoble Alpes, Grenoble INP, GIPALAB, 38000 Grenoble, France.

³Univ. Grenoble Alpes, Grenoble INP, LCIS, 26000 Valence, France.

⁴Centre Technique du Papier, Domaine Universitaire, 38044 Grenoble, France.

Abstract—In this work, we propose a THz tag structure based on a stack of different dielectric layers made of PE and PE-TiO₂ mixture, in which we voluntarily randomly deposit metallic flakes. Due to the randomness of the flake distribution (position and size), such a structure exhibits a potential unique THz signature that could be used to address identification using targeted statistical analysis via the 2D correlation coefficient and a SIWPD analysis. The signature is obtained by making a 2D THz image of a given area of the structure.

I. INTRODUCTION

The THz tagging technology (THID) has been recently developed in order to address identification applications [1,2]. Contrary to RFID, the THz approach allows to encode the information in the volume by using structure of small size (in the millimeter range), which makes the possibility of reverse-engineering more difficult. In this study, we developed tags in which a random information is used to unitary identify any tag from each other. The basic structure (Fig. 1.a) is made of a dielectric stack composed of 5 different layers (as encounter for example in smart cards structures) with different thicknesses and refractive indices. We use a mixture of polyethylene (PE) and TiO₂ whose ratio varies to finely tune the effective refractive index of each consecutive layer. Moreover, metallic flakes of the order of the mm in lateral dimensions were randomly deposited between the 2nd and the 3rd layer (grey layer in Fig. 1a).

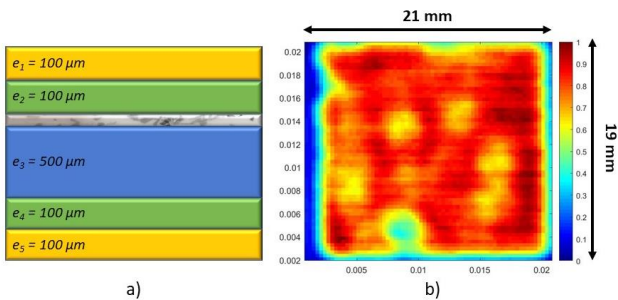

Fig. 1. a) Scheme of the structure used as tag, and b) the associated THz image (peak THz pulse amplitude).

II. RESULTS

Here, the tag structure is imaged pixel by pixel with a homemade THz-TDS imaging system whose bandwidth range spreads up to 4 THz. The pattern of each picture is 63 x 67=4221 pixels with a spatial increment of 300 μm (Fig. 1.b). The colormap represents the waveform magnitude transmitted through the tag relatively to the reference signal reference signal obtained without tag. Consequently, the yellow parts reveal low transmission

corresponding to the metallic flakes agglomerates. As the beam diameter is of the order of 3 mm compare to the one of the flake (~1 mm) : the transmission at the position of the flake cannot be totally null. In the present study, we image 3 tags constituted of same layers except the random one. The measure 4 images per tag consecutively without removing the tag. To address identification, we arbitrarily consider one of these 12 pictures, taken on one of the tags, as the reference one. We then calculate the 2D correlation

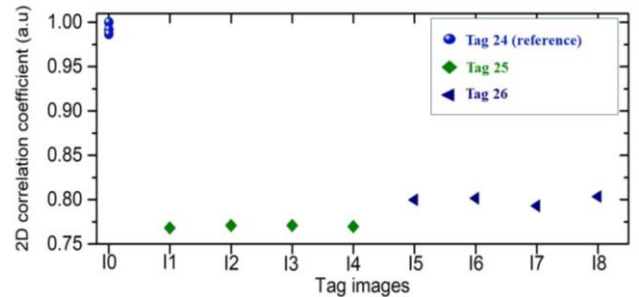

Fig. 2. 2D correlation coefficients calculated from the reference tag on the 4 different images of the other tags.

coefficients between this reference THz image and all of them, including the one considered as the reference. In Fig. 2, we can see that the 2D correlation coefficient keeps very close to 1 if we take into account images from the reference tag. Conversely, it drops down to 0.77 and 0.80 when calculated with all the images from the other tags, showing that it becomes possible to discriminate such THz tag structures between each other, simply using 2D correlation coefficient. In order to even more clearly identify the tag's class, image analysis method will be proposed. Let notice that the discriminating elements exhibit ellipsoidal-like shapes (Fig. 1b), with different size, shape (if superimposed) and at different places. To detect and properly classify them, we apply a Shape Invariant Wavelet Packet Decomposition (SIWPD) followed by the distance calculation between the wavelet coefficients [3]. The main feature of the SIWPD are the data driven design of the analyzing wavelet function as well as the definition of an appropriate distance between wavelet coefficients for an optimal identification performance. The Wavelet Packet Decomposition (WPD) allows the representation of any signal/image in spectral subspaces [4], where the approximations and the image details are presented: h – low pass filter; g – high pass filter; $\downarrow 2$ – is the down-sample operator of order 2 (retain only one coefficient from consecutive 2) (Fig. 3). The WPD offers the possibility to identify the best basis decomposition according to an information measure [5].

The most useful one is the entropy computed for each image subspace. If x is a given image subspace (sub-band), the entropy is defined by:

$$\eta(x) = -\sum_j p_j \log p_j, p_j = \frac{|x_j|^2}{|x|^2} \quad (1)$$

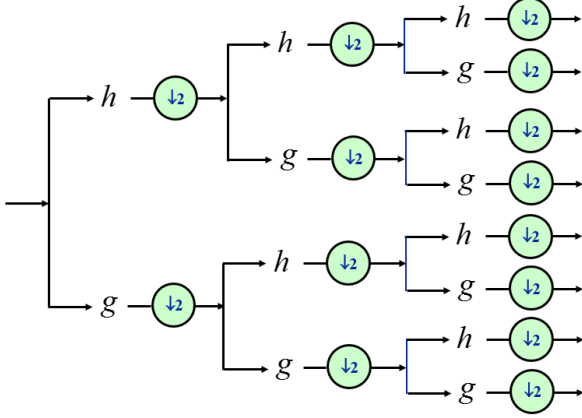

Fig. 3: Three level wavelet packet decomposition. This diagram is designed for a 1D array but in the case of images, this diagram is done successively on lines and then on columns. For an image, the wavelet packet decomposition is organized as defined by the next image.

The idea of the Best Basis (BB) selection is to realize the subspace decomposition if the split of a subspace $W_j^{(p,q)}$ (parent sub-space) in a higher resolution level, of four sub-spaces (children) nodes only if the entropy is minimized (Fig. 4). The problem of this classical algorithm is the variance of the best basis when the image content (even the same one) is not spatially constantly distributed, from one image to another. The modified image is the shifted one and the best basis selection from WPD leads to a different

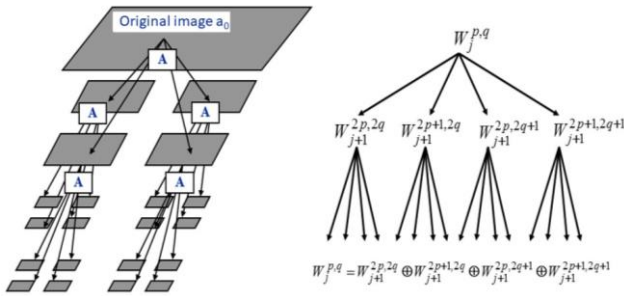

Fig. 4: Two level 2D wavelet packet decomposition.

best basis although the image content is the same. This problem is solved by using the Shift Invariant WPD (SIWPD) [6] but the algorithm implementation is under patent protection in progress (Grenoble INP/GIPSA-lab property). The best basis will be used to compare two tag images in order to classify them. For this, we define the best basis distance (BBD), computed from SIWPD, between the best basis of the two images. If the BB_img1 and BB_img2 are the binary vectors coding the best basis of two images ($img1$ and $img2$) the BBD is defined as:

$$BBD\{img1, img2\} = \| BB_img1 - BB_img2 \| \quad (2)$$

The best basis binary coding is done as follows: if a given subspace is decomposed, then, it is coded by 0. If it is a final node, then, it is coded by 1. The approach defined previously has been applied to three classes of images, each of them containing four images. The BBD computed between all the image pairs shows that, using the BBD metrics, it is possible to organize the images in the clusters corresponding to their classes. More precisely, the variance of the BBD computed for the images of the same class is much lower than the variance of the BBD computed for images belonging to different classes: Intraclasse and Interclasse considering the same images of one tag, and between tags couple, respectively (Fig. 5). This proves that the BBD can be usefully used to identify the type of tags, with respect of pre-defined clusters.

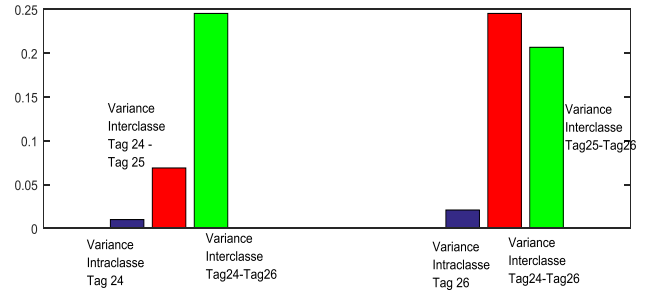

Fig. 5: Variance interclasses calculated on the same measurements of one tag (intraclasse) and between each tags couple (interclasse).

III. CONCLUSION

We show the possibility to efficiently discriminate tags in the THz domain by using structures made of dielectric materials and containing random elements with size of the order of the mm, in order to increase the level of security of the commonly used RFID solutions for identification of products. For that, we propose two methods: 1) by simply calculating the 2D correlation coefficients between the different THz images of the tags. 2) We also showed that a 2D wavelet packet decomposition (SIWPD) can be powerful as it leads to an efficient classification of all these tags images. More quantitative results will be presented during the conference in order to compare the performances of the two methods.

ACKNOWLEDGMENT

This work is supported by the ANR AUSTRALE project, grant ANR-18-CE39-0002 of the French Agence Nationale de la Recherche.

REFERENCES

- [1]. M. Bernier, F. Garet, E. Perret, L. Duvillaret, S. Tedjini, "THz encoding approach for secured chipless radio frequency identification" *Appl. Opt.*, vol. 50, no. 23, pp. 4648-4655, 2011.
- [2]. Z. Ali, F. Bonnefoy, R. Siragusa, N. Barbot, D. Hely, E. Perret, and F. Garet, "Potential of chipless authentication based on randomness inherent in fabrication process for RF and THz". *IEEE 11th European Conference on Antennas and Propagation*, pp. 2559-2563, 2017.
- [3]. J. Bonnel, A. Khademi, S. Krishnan and C. Ioana, "Small bowel image classification using cross-co-occurrence matrices on wavelet domain", *Journal on Biomedical Signal Processing and Control*, vol. 4, no. 1, pp. 7-15, 2009.
- [4] R.R. Coifman – "Wavelet Analysis and Signal Processing", in *Signal Processing Part 1 : Signal Processing Theory. L. Auslander et al.eds., IMA. Vol. 22, Springer, New York. 1990.*

- [5] S. Mallat – “A wavelet tour of signal processing”, *Academic Press, 1998*.
- [6] I. Cohen, “Shift-Invariant Adaptive Wavelet Decomposition and Applications”, *Research Thesis, Israel Institute of Technology, 1998*.