



HAL
open science

Impact of a reinforced concrete roof slab by falling rocks: experiments and modeling

Philippe Berthet Rambaud, Pascal Perrotin, Yehya Timsah, Michel Mommessin, Jean Pierre Mougin, Jacky Mazars, Laurent Daudeville

► **To cite this version:**

Philippe Berthet Rambaud, Pascal Perrotin, Yehya Timsah, Michel Mommessin, Jean Pierre Mougin, et al.. Impact of a reinforced concrete roof slab by falling rocks: experiments and modeling. Italian Geotechnical Journal, 2004, 2, pp.45-53. hal-02003245

HAL Id: hal-02003245

<https://hal.univ-grenoble-alpes.fr/hal-02003245v1>

Submitted on 14 Feb 2019

HAL is a multi-disciplinary open access archive for the deposit and dissemination of scientific research documents, whether they are published or not. The documents may come from teaching and research institutions in France or abroad, or from public or private research centers.

L'archive ouverte pluridisciplinaire **HAL**, est destinée au dépôt et à la diffusion de documents scientifiques de niveau recherche, publiés ou non, émanant des établissements d'enseignement et de recherche français ou étrangers, des laboratoires publics ou privés.

Impact of a reinforced concrete roof slab by falling rocks: experiments and modeling

Philippe Berthet-Rambaud,* Pascal Perrotin,** Yehya Timsah,*** Michel Mommessin,**
Jean-Pierre Mougin,** Jacky Mazars,**** Laurent Daudeville****,¹

Summary

In mountainous areas where the falling rocky blocks constitute a major hazard to civil structures, the structural systems to protect roads and vehicles are usually rock sheds composed of over dimensioned reinforced concrete elements. This is mainly due to the lack of knowledge of the dynamic effects caused by these falling rocks. A thick backfilling layer that prevents the direct impact of falling rocks by constituting a damping medium commonly covers the roof slab of protection structures. This allows the design of the slab with static dead loads (backfilling, concrete roof and rock weights). Recent experiments were performed in Chambéry France on a new type of protection system characterized by a roof slab without damping medium (no backfilling) and simply supported on vertical elements by a set of "fuse" steel supports. The roof slab resists directly the falling rocks impacts, which cause limited local damage to the impact zone, in case of field impact, or the yielding of steel supports for boundary impact cases. This new protection system makes it possible to reduce the costs considerably by reducing the dimensions of both the concrete structure and its foundations, it allows continuous uses of the structure through the repair of the damaged zones in the roof slab or the replacement of the "fuse" steel support after each impact. The aim of the present study is to predict the structural response of the new proposed system by a rigorous three-dimensional modeling of the roof slab and its supporting elements. The analysis introduces the impact load in a way similar to that of the performed experiment, and a stress-strain concrete relationship that allows a realistic representation of the concrete behavior under dynamic loads and its corresponding damages. The comparison of the experimental measurements with those obtained from the present analysis proves the accuracy of the built model in predicting the real behavior of the protection structure.

Key words: rock-fall, impact, concrete, experiment, modeling, finite element method

1. Introduction

The continuous expansion of urban zones in mountain regions increases the need of protection systems that protect the civil structures and infrastructures from natural hazards such as snow avalanches, falling rocks, and landslides. The dimensioning and designing of reinforced concrete protection systems is based, in the current codes of practice, on approximate method that consider the straining forces as static forces. The use of approximate static analysis methods leads either to over-dimensioned protection systems (massive concrete elements in usual gallery protection systems against rock fallings), or to under dimensioned systems.

The optimal dimensioning of protection systems (strength + limited cost) should be based on the following conditions:

- Considering the dynamic feature of the loading.
- Using behavior properties for the structural materials that allow an accurate description of the stress-strain relationship variation under the applied dynamic loads.
- Performing numerical structural analysis that includes realistic problem data (three dimensional geometry, generation of dynamic effects due to impacts, non-linear behavior...).

The present study focuses on the gallery rock falling protection system, conventionally composed of reinforced concrete sub-structural elements (walls, columns, and foundations) and a roof slab covered by a thick backfilling layer (Fig. 1). The roof slab is rigidly connected to sub-structural elements, and the backfilling layer constitutes a damping medium, and allows therefore, the design of the system with only static dead loads (own weight, backfilling and rock weights).

The structure is not designed any more to resist the impact of blocks but especially to support the backfilling layer. This solution has the main disadvantage of producing over dimensioned reinforced concrete elements. The foundations, which must be dimensioned consequently, cause often some site

* Cemagref, Grenoble, France and CETE, Lyon, France

** LOCIE, Le Bourget du Lac, France

*** Beirut Arab University, Beirut, Lebanon

**** Laboratoire Sols Solides Structures, Grenoble, France

¹ Author to whom all correspondence should be addressed
e-mail: Laurent.Daudeville@hmg.inpg.fr

construction problems as for the case of a raised slope, a weak soil...

Considering that the request for this type of equipment will be increasing, an investigation was carried out to improve the design and limit costs. The basic idea was to eliminate the backfilling layer and to use a semi-probabilistic approach with the notion of "acceptable damage" to the structure.

For the purpose of finding an optimal solution, a new system was proposed in France by the consulting company TONELLO IC, which consists of a roof slab pin supported (no continuity) on the sub-structural elements. The roof slab is subjected to the direct impact of falling rocks and slab reactions are transmitted to the sub-structures throughout ductile steel supports that act as dissipating energy fuses and protect the sub-structural elements (Figs. 2 and 3). The slab is then designed in order to resist directly to a falling rock impact that causes a local damage limited to the shock zone in case of field impact

The first example of this protection system was built in 1999 at "Les Essariaux" between Albertville and Chamonix in the French Alps.

2. Experiments

During June and July 2001, the TONELLO IC company has performed experiments in collaboration with the LOEIE (University of Chambéry) on a one third reduced scale system model of the roof slab of the proposed new system in order to evaluate the response and the performance of this system.

The concrete slab dimensions are 12 m × 4.4 m × 0.28 m. The concrete compressive strength is 32.4 MPa, the reinforcement strength is 500 MPa and its quantity is quite high (4.3 tons). The slab is set on two lines of 11 steel fuses (12.6 cm high and spaced at 1.14 m) and impacted by a 450 kg reinforced concrete cubic block (58 cm side) falling from different heights to various locations of the slab.

The slab design was performed using a simplified method based on the principle of momentum and energy conservations [TONELLO, 2001; PERROTIN *et al.*, 2002]. Assuming that the governing flexural deformed shape is the first mode of vibration for the impacted slab, the slab mass is substituted by an equivalent mass M^* (Fig. 4):

$$M^* = \int \frac{y_i^2}{y_0^2} dm \quad (1)$$

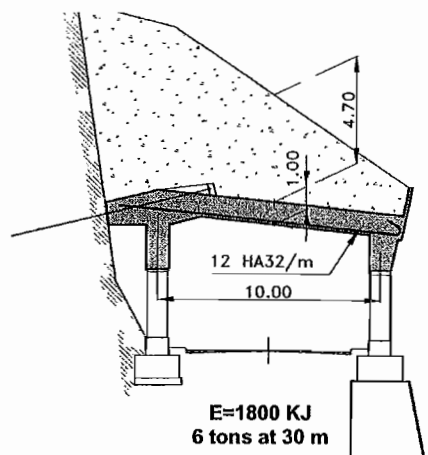

Fig. 1 – Conventional rock shed.
Fig. 1 – Opera di protezione convenzionale.

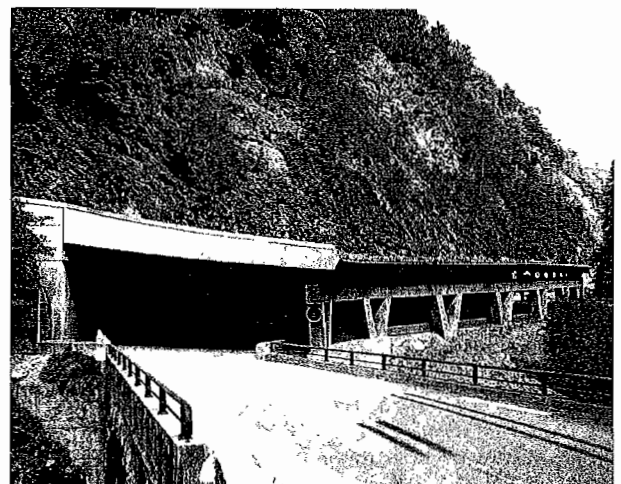
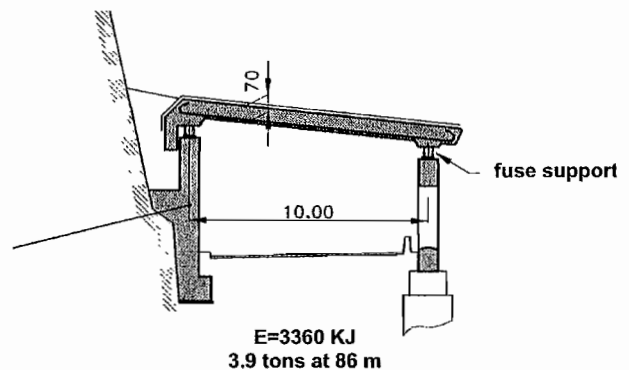

Fig. 2 – New rock shed system, Gallery "Les Essariaux".
Fig. 2 – Nuovo sistema di protezione, Galleria "Les Essariaux".

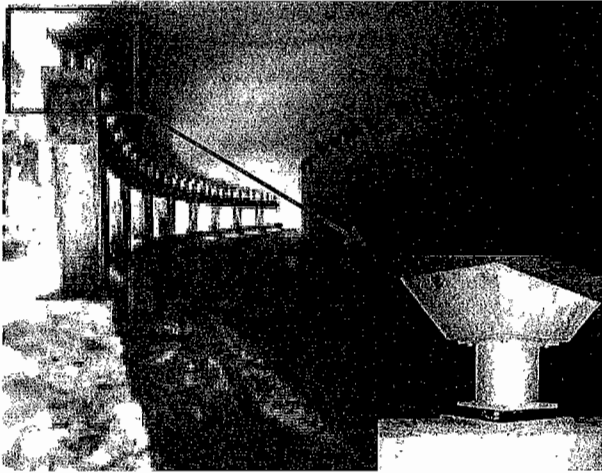

Fig. 3 – New rock shed system, Gallery “Les Essariaux” – and a fuse support.

Fig. 3 – Nuovo sistema di protezione (Galleria “Les Essariaux”), con vista di dettaglio dell'appoggio che funge da elemento dissipatore.

where y_0 is the amplitude of the flexural deformation of the slab, y_i is the displacement of the partial mass dm of the slab.

Assuming also that after the impact there were neither a bounce of the projectile nor a penetration into the slab, the principle of momentum and energy conservations leads to the following relation:

$$E \frac{m}{M^* + m} = P_u (0.5f_e + f_p) \quad (2)$$

where m and E represent the mass and the kinetic energy of the mass respectively. The right hand side represents the dissipated energy in the slab; P_u is the peak impact force, f_e and f_p represent the elastic and plastic strains respectively assuming an elastic plastic behavior of the slab with no hardening. The slab thickness and the reinforcement bars are then calculated with the static force P_u according to service or ultimate limit states (Fig. 4).

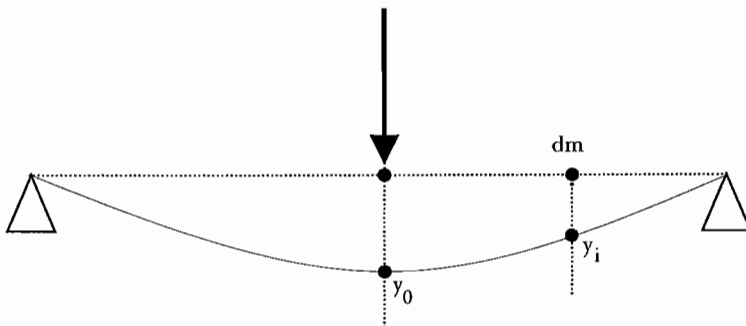

Fig. 4 – Simplified model used for the design of the concrete slab.

Fig. 4 – Modello semplificato per il progetto della piastra di calcestruzzo armato.

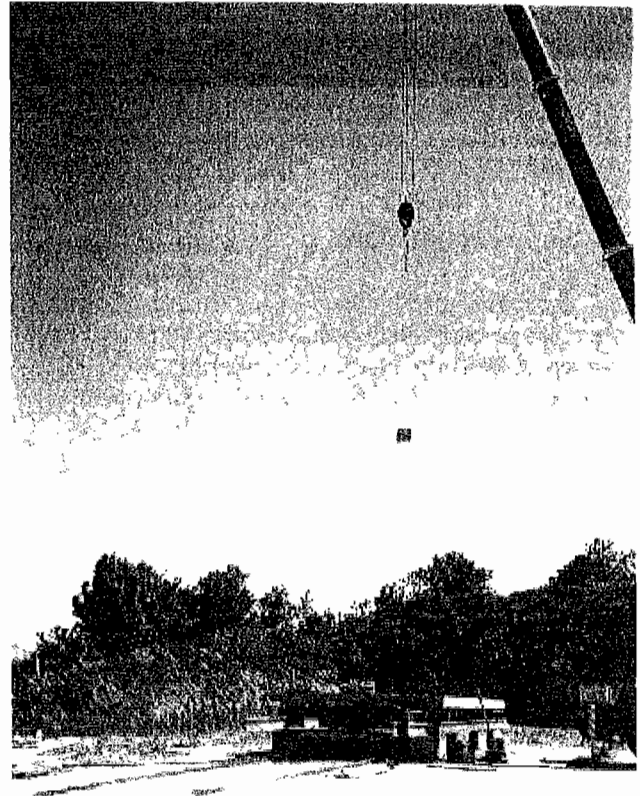

Fig. 5 – Rock fall test.

Fig. 5 – Prova di impatto per caduta di un blocco.

The concrete block was released to fall freely from 15 and 30 m high, and to impact the slab, almost on one of its faces. The impact velocity varied from 17.2 to 24.2 m/s and the kinetic energy from 67.7 to 135 kJ (Fig. 5).

Three impacts were carried out: the first and the second from 15 and 30 m high in the inner part of the slab and the third from 30m on the edge of the slab (the support line).

The slab response to the different impacts was obtained through general displacement measurements and with strain gauges.

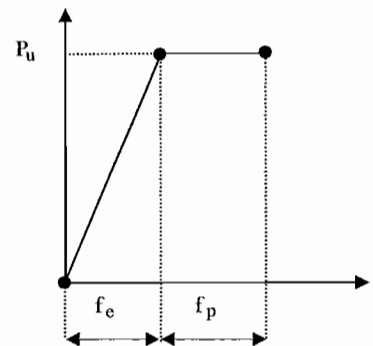

These relatively large-scale experiments provide interesting and complete data that allow better understanding of the structural response to impact loads. They also allow the evaluation of the numerical analysis performance of the modeled structure.

3. Numerical Analysis

A realistic prediction of the structural response through numerical analysis requires rigorous three-dimensional finite elements modeling of the different structural components. In the present study, the finite elements code Abaqus was used. The explicit module of this code allows highly non-linear transient dynamic analysis of phenomena like impacts.

Abaqus offers also the possibility of managing several interactive entities (the slab and the block in the present case). The analysis can, therefore, introduce the impact in a way similar to that of the experiment, managing only the impact characteristic.

Finite element modeling

The slab and the block were modeled with volumetric finite elements (Figs. 6 and 7) with different mesh refinements (essentially at the impact zones of

the slab). The reinforcement was represented by bar elements or with the Abaqus "rebar" option that uses a superposition of stiffness matrix method.

The steel supports were modeled with volumetric elements (Fig. 8). The conditions of contact with friction between the steel fuse, the slab, and the rigid concrete floor by means of elastomer layers were taken into account.

Constitutive behavior modeling of concrete

For an accurate simulation of the structural response, it is necessary to use a realistic representation of the materials behavior under dynamic loads. For the concrete, the behavior properties must include some phenomena that are related to the damage under dynamic loads such as decrease in material stiffness due to cracking, stiffness recovery related to closure of cracks, and inelastic strains concomitant to damage.

The stress-strain relationship was represented in the numerical analysis by the PRM (Pontiroli-Rouquand-Mazars) damage model shortly presented hereafter. The complete description of the model can be found in [PONTIROLI, 1995; ROUQUAND and PONTIROLI, 1995]. The model uses two scalar damage indicators in tension (D_t) and in compres-

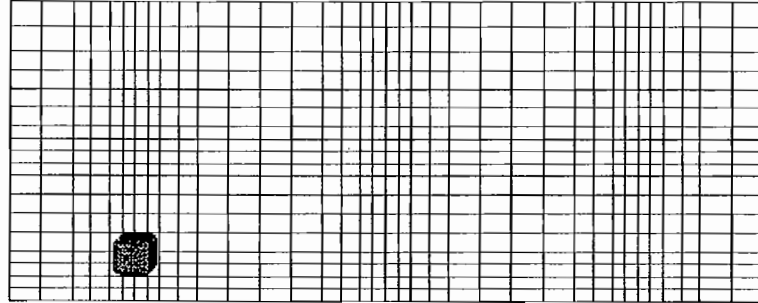

Fig. 6 – Top view of both the slab and the block.

Fig. 6 – Vista dall'alto del modello ad elementi finiti della piastra e del blocco.

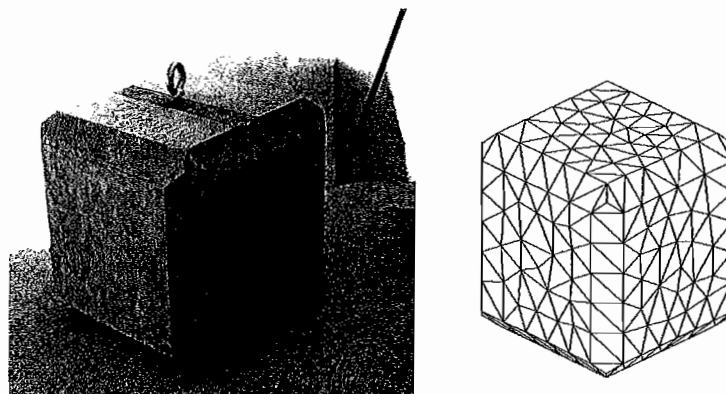

Fig. 7 – Photography and 3D model of the concrete block.

Fig. 7 – Fotografia e modello tridimensionale del blocco di calcestruzzo.

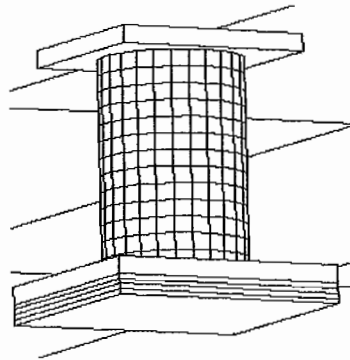
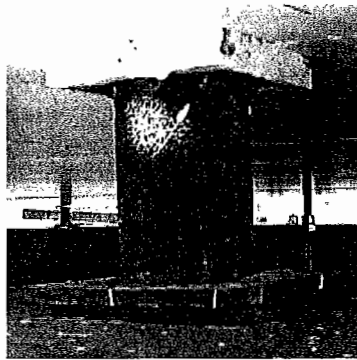

Fig. 8 – Photography and 3D model of a steel support.
 Fig. 8 – Fotografia e modello tridimensionale di un appoggio in acciaio.

sion (D_c). These damage variables vary from 0 (for uncracked material) to 1 (for macro-cracked material). Figure 9 shows the uni-dimensional response of the model under a cyclic loading. As shown on the figure, when the stress σ is greater than a closure stress σ_{ft} , a tensile behavior is obtained and D_t controls the stiffness. When σ is lower than σ_{ft} , D_c gives the relative variation of the stiffness in compression. The three-dimensional expression of stress-strain relationship is the following:

$$(\sigma - \sigma_{ft}) = (1 - D_t) \alpha_t [\lambda_0 \text{Tr}(\varepsilon - \varepsilon_{ft}) \mathbf{I} + 2 \mu_0 (\varepsilon - \varepsilon_{ft})] + (1 - D_c) \alpha_c [\lambda_0 \text{Tr}(\varepsilon - \varepsilon_{ft}) \mathbf{I} + 2 \mu_0 (\varepsilon - \varepsilon_{ft})] \quad (3)$$

$\text{Tr}(\varepsilon)$ indicates the trace of the tensor ε , \mathbf{I} is the unit tensor. σ and ε are the stress and strain tensors respectively, λ_0 and μ_0 are the Lamé coefficients. σ_{ft} is the closure stress tensor, this stress state defines the transition state between tension and compression, ε_{ft} is its associated strain tensor. The closure stress decreases as the compressive damage grows, σ_{ft} can be written as:

$$\sigma_{ft} = (1 - D_c)^2 \sigma_{ft0} \quad (4)$$

σ_{ft0} is the initial closure stress tensor and ε_{ft0} is its associated strain tensor. α_t and α_c are scalar values that give the compressive and tensile respective parts of any loading. α_t and α_c are calculated from the effective stress tensor ($\tilde{\sigma} - \tilde{\sigma}_{ft}$):

$$\tilde{\sigma} - \tilde{\sigma}_{ft} = \lambda_0 \text{Tr}(\varepsilon - \varepsilon_{ft}) \mathbf{I} + 2 \mu_0 (\varepsilon - \varepsilon_{ft}) \quad (5)$$

If $\text{Tr}(\tilde{\sigma} - \tilde{\sigma}_{ft}) < 0$ then $\alpha_t = \frac{\sum \langle (\tilde{\sigma} - \tilde{\sigma}_{ft})_i \rangle_+}{|\sum \langle (\tilde{\sigma} - \tilde{\sigma}_{ft})_i \rangle|}$ else $\alpha_t = 1$

(6)

$$\alpha_t + \alpha_c = 1 \quad (7)$$

$\langle \sigma_i \rangle_+$ indicates the positive part of the i^{th} principal stress of tensor σ . From the strain tensor ε and from the material parameter ε_{fc} (Fig. 9), it is possible to calculate the compressive damage variable D_c and

its increment \dot{D}_c . The variations of D_c is governed by the equivalent strain $\tilde{\varepsilon}_M$ [MAZARS, 1984 and 1986] related to the micro crack opening in mode I:

$$\tilde{\varepsilon}_M = \sqrt{\sum \langle \varepsilon_i \rangle_+^2} \quad (8)$$

The closure strain increment $\dot{\varepsilon}_{ft}$ is obtained from the \dot{D}_c value and from the strain tensor ε . Integration versus time of $\dot{\varepsilon}_{ft}$ gives ε_{ft} . Then the reversible strain tensor $(\varepsilon - \varepsilon_{ft})$ allows computation of the tensile damage variable D_t which is controlled by an equivalent strain $\tilde{\varepsilon}$:

$$\tilde{\varepsilon} = \sqrt{\sum \langle (\varepsilon - \varepsilon_{ft})_i \rangle_+^2} \quad (9)$$

The damage variables in tension (D_t) and compression (D_c) satisfy the following equation [MAZARS, 1984 and 1986; PONTIROLI, 1995]:

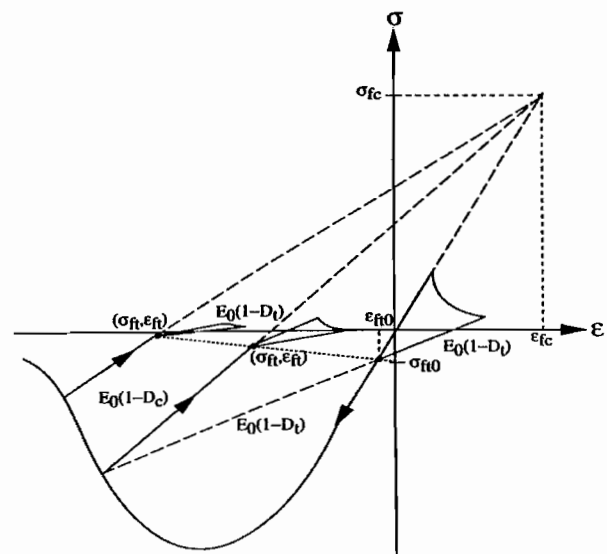

Fig. 9 – PRM modeling of the concrete behavior.
 Fig. 9 – Modello PRM per il comportamento del calcestruzzo.

$$D = 1 - (1 - A_\alpha) \frac{\varepsilon_0}{\hat{\varepsilon}} - A_\alpha e^{-B_\alpha(\hat{\varepsilon} - \varepsilon_0)} \quad \alpha = c, t \quad (10)$$

$$\text{With } \hat{\varepsilon} = \tilde{\varepsilon}_M \text{ if } \text{Tr}(\varepsilon - \varepsilon_n) \leq 0 \text{ else } \hat{\varepsilon} = \tilde{\varepsilon} \quad (11)$$

The parameters A_α and B_α are given in PONTIROLI [1995]. The damage evolutions (10) depend on a strain threshold ε_0 given by:

$$\varepsilon_0 = \alpha_t \varepsilon_0^t + \alpha_c \varepsilon_0^c \quad (12)$$

ε_0^t and ε_0^c are the strain thresholds in tension and compression respectively. They depend on the strain rate $\dot{\varepsilon}$ in order to model the strain rate effect under dynamical loading [SUARIS and SHAH, 1984]:

$$\varepsilon_0^t = \varepsilon_0^t (1 + a_t (\dot{\varepsilon})^{b_t}) \text{ and } \varepsilon_0^c = \varepsilon_0^c (1 + a_c (\dot{\varepsilon})^{b_c}) \quad (13)$$

ε_0^t , a_t , b_t , a_c and b_c are material parameters identified from data available in the literature [BISCHOFF and PERRY, 1991; BRARA and KLEPACZKO, 2001].

All terms of Equation (3) can be obtained directly without any iterative process. This three dimensional model was implemented in Abaqus-Explicit using an external Fortran subroutine. The PRM model parameters were identified from the characteristic strengths of materials, the results presented in the following chapter were obtained with no fitting. The dependency of the results with respect to the model parameters can hardly be performed since every impact simulation is time con-

suming. The dependency of the model response in tension and compression with respect the model parameters is given in PONTIROLI [1995].

The stress-strain relationship for the reinforcing bars is considered as simply elastic plastic, with hardening or without hardening.

No steel-concrete debonding was modeled for two reasons. First, this damage model is able to reproduce a stress concentration in concrete close to the reinforcement bars and then to model a possible associated damage. The second reason is that no steel-concrete debonding was observed after the tests.

The HILLERBORG *et al.* [1976] regularization technique is used in order to avoid mesh dependency.

4. Analysis Results

A wide range of results was obtained from the different loadings cases (impacts locations and falling heights), the modeling of steel supports (non-linear springs versus 3D complete model), and the reinforcement modeling (rebar versus bar elements).

Figure 10 shows the transversal profiles of the measured maximum slab deflection during the test number 1 (Tab. I). Figure 11 shows the evolution with time of this vertical displacement during the test number 1. The comparison of analysis results and experiment measurements can only be carried

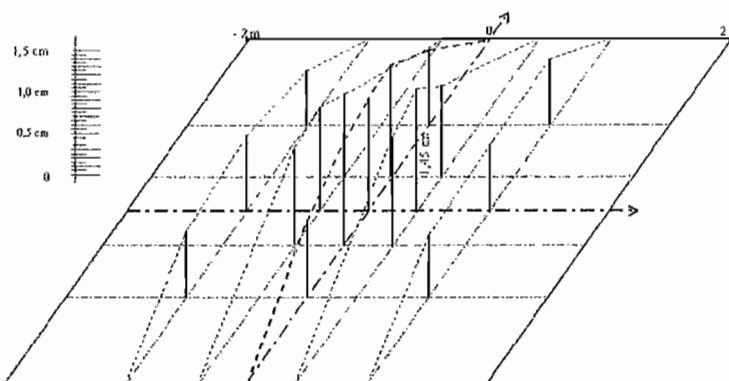

Fig. 10 – Transverse profiles of measured maximum vertical displacements.

Fig. 10 – Profili degli spostamenti verticali massimi misurati.

Tab. I – Measured and calculated vertical displacements.

Tab. I – Spostamenti verticali misurati e calcolati.

Test number	Height fall	Impact point	Measured vertical displacement	Calculated vertical displacement
1	15 m	inner part	14.5 mm	15.2 mm
2	30 m	inner part	23.0 mm	22.2 mm (13.3 mm if elastic materials)
3	30 m	support line	21.5 mm	21.2

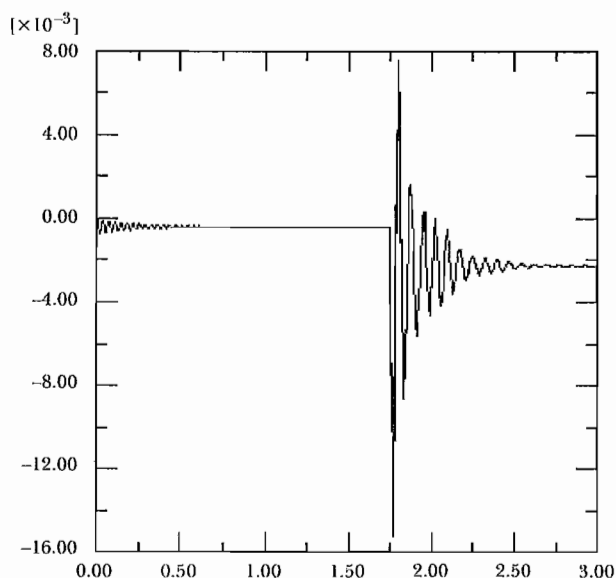

Fig. 11 – Displacement of the sub-face of the slab at the location of impact versus time.

Fig. 11 – Andamento nel tempo dello spostamento all'intradosso della piastra nel punto di impatto.

out quantitatively with the vertical displacement of the under-surface of slab vertically to the impact point (Tab. I). Table I shows a global agreement between the calculated and measured results, which indicates a good performance of the model in predicting the real behavior of the structure.

Note the prediction of the maximum vertical displacement with an elastic behavior for concrete gives a very different result in case of test number 2 (Tab. I). That last result confirms the necessity of modeling the non linear behavior of concrete.

The 3D modeling of steel supports gave a deformed shape similar to that obtained in reality (Fig. 12).

The advantage of this type of analysis, in addition to traditional analysis output (strain, stress, in-

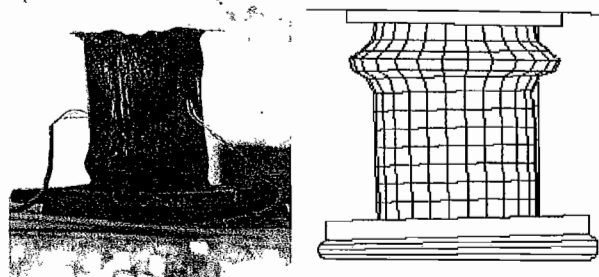

Fig. 12 – Deformed shape of the experimental and modeled steel support.

Fig. 12 – Configurazione deformata dell'appoggio in acciaio, osservata nell'esperimento e calcolata con il modello agli elementi finiti.

ternal forces, reactions...), is to allow obtaining additional type of results throughout the implemented subroutine. In particular evaluating the damage states by mapping the values of damage variables in the slab. Figure 13 shows the damage localization, i.e. the values of damage on the sub-face of the slab due to different impacts.

The repartition of damages within the slab thickness can also be obtained. Whereas further investigations has to be performed into the relationship between the damage variable values and the real state of damage, initial comparison of experimental and numerical results for the described tests showed an qualitative agreement between damage repartition obtained from the analysis and that observed with the experimentation (Figs. 13 and 14) (spalling, radial cracking...).

5. Conclusion

The evaluation of the performance of the new proposed system for reinforced concrete galleries was the main aim of this study. This was achieved by

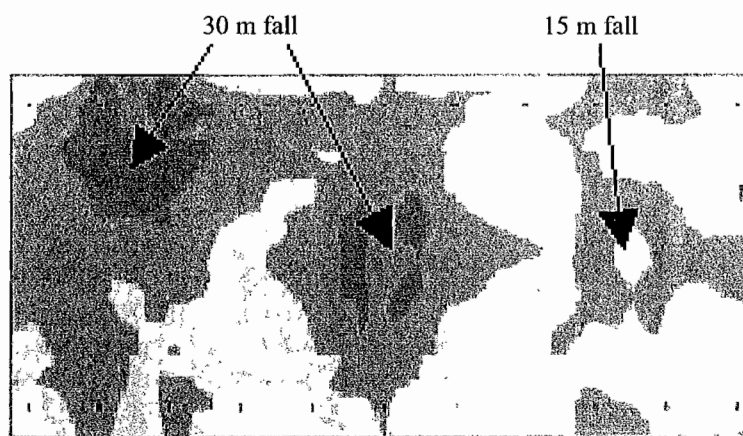

Fig. 13 – Mapping of damage distribution in the slab.

Fig. 13 – Distribuzione spaziale del danneggiamento nella piastra.



Fig. 14 – Damage pattern on the sub-face of the slab.

Fig. 14 – Danneggiamento all'intradosso della piastra, con fenomeni di distacco del calcestruzzo.

a numerical analysis including: a 3D model of the structural elements (block, slab, and the steel supports), a damage mechanics based model for concrete, and a realistic representation on the straining actions (different impacts of the projectile).

The numerical analysis allowed also the evaluation of the influence of different parameters as the impact velocity of the block, the block mass, the bearing capacity of the fuses, the material characteristics...

The analysis results proved to be in agreement with the experimental measurements, as well as representing the damage states after the three impacts.

Based on the obtained experimental and numerical results it can be concluded that:

- The new proposed system well fits its uses: optimal dimensioning, ability to resist blocks impacts that cause repairable damages, this would be done without affecting the serviceability state of the structure,
- The numerical modeling represents a powerful mean in predicting the behavior of this type of structures, and can therefore be used for their design.

Further research must however be performed to include additional cases such as the response of a repaired slab to new impacts, the structure response when subjected to several consecutive impacts.

References

- BISCHOFF P.H., PERRY S.H. (1991) – *Compressive Behavior of Concrete at High Strain Rates*. Materials and Structures, 24, pp. 425-450.
- BRARA A., KLEPACZKO J. (2001) – *An Experimental Method for Dynamic Tensile testing of Concrete by Spalling*, International Journal of Impact Engineering, 25, pp. 387-409.
- HILLERBORG A., MODER M., PETERSSON P.E. (1976) – *Analysis of Crack Formation and Growth in Concrete by Means of Fracture Mechanics and Finite Elements*. Cement and Concrete Research, 6, pp. 773-782.
- MAZARS J. (1984) – *Application de la mécanique de l'endommagement au comportement non linéaire et à la rupture du béton*. Thèse de doctorat d'état, Univ. Paris VI, Paris, France.
- MAZARS J. (1986) – *A Description of Micro-and Macro-Scale Damage of Concrete Structures*. Engineering Fracture Mechanics, 25 (5/6), pp. 729-737.
- PERROTIN P., MOMMESSIN M., MOUGIN J.P., TONELLO J. (2002) – *Etude Expérimentale du Comportement d'une Dalle Pare-Bloc*. Revue Française de Génie Civil, 6 (5), pp. 723-734.
- PONTIROLI C. (1995) – *Comportement au souffle des structures en béton armé, analyse expérimentale et modélisation*. Thèse de l'ENS Cachan, Cachan, France.
- ROUQUAND A., PONTIROLI C. (1995) – *Some Considerations on Implicit Damage Models Including Crack Closure Effects and Anisotropic Behavior*. Proc. FRAMCOS-2, F.H. Wittmann, (Ed.), AEDIFICATIO Publisher, Freiburg, Germany.
- SUARIS W., SHAH S.P. (1984) – *Rate-sensitive damage theory for brittle solids*. ASCE, J. of Structural Engineering, 111 (3), pp. 563-576.
- TONELLO J. (2001) – *Couverture pare-blocs structurellement dissipante*. Label IVOR 01.1. Mission Génie Civil, METL/DRAST. <http://www.equipement.gouv.fr/recherche/incitatif/ivor>.

Effetto dell'impatto di blocchi sul tetto in cemento armato di gallerie paramassi: esperimenti e modellazione

Sommario

Nelle regioni montane, in cui la caduta di massi costituisce un rischio reale ed importante, la protezione della sede stradale è spesso assicurata da gallerie paramassi. Queste comprendono piastre in calcestruzzo armato, che sono tipicamente sovradimensionate – ciò essenzialmente a causa della scarsa conoscenza degli effetti dinamici legati all'impatto provocato dalla caduta dei massi. Le piastre sono tipicamente ricoperte da uno strato di materiale sciolto assorbente, di elevato spessore. Una campagna di prove di impatto è stata recentemente condotta a Chambéry (Francia) su una tipologia innovativa di gallerie paramassi, caratterizzata dall'assenza dello strato assorbente. La piastra in cemento armato è appoggiata su elementi verticali in acciaio che fungono da dissipatori, e che rappresentano gli

elementi "fusibili" del sistema. In questo caso, la piastra è direttamente soggetta all'impatto, il che provoca un danneggiamento locale nella zona di impatto, ovvero lo snervamento degli elementi di appoggio. Questa nuova tipologia di protezione dalla caduta di massi consente di ridurre sostanzialmente i costi dell'opera (dimensioni della struttura in cemento armato, fondazioni); essa rende inoltre possibili continui interventi di riparazione dell'opera – sia delle zone di calcestruzzo danneggiato, sia degli elementi fusibili, che possono essere sostituiti dopo ciascun impatto.

Nel presente lavoro, viene illustrato un esempio di analisi numerica della risposta strutturale del sistema proposto all'impatto di un blocco. L'analisi, tridimensionale, è stata effettuata mediante il metodo degli elementi finiti. Le caratteristiche geometriche del sistema e quelle dell'impatto (dimensione del blocco, velocità di caduta, angolo di impatto) sono analoghe a quelle sperimentali. Per il comportamento meccanico del calcestruzzo, si è adottato il modello di danneggiamento proposto da PONTIROLI, ROUQUAND e MAZARS. Il confronto tra risultati sperimentali e previsioni numeriche appare soddisfacente.